

4

3

2

1

**ATTENTION**  
 THIS DOCUMENT AND THE DATA DISCLOSED HEREIN OR HEREWITH IS NOT TO BE REPRODUCED, USED, OR DISCLOSED IN WHOLE OR IN PART WITHOUT THE EXPRESSED, WRITTEN PERMISSION OF REYMOND PRODUCTS AND IS SUBJECT TO RETURN UPON REQUEST

REVISIONS				
ECN	REV.	DESCRIPTION	BY	DATE
-	00	ORIGINAL RELEASE	dar	11/06/2012
-	01	ADDED 1095K13 GREASE ZERK; REMOVED 2309K91 GREASE ZERK	JLB	07/24/2013

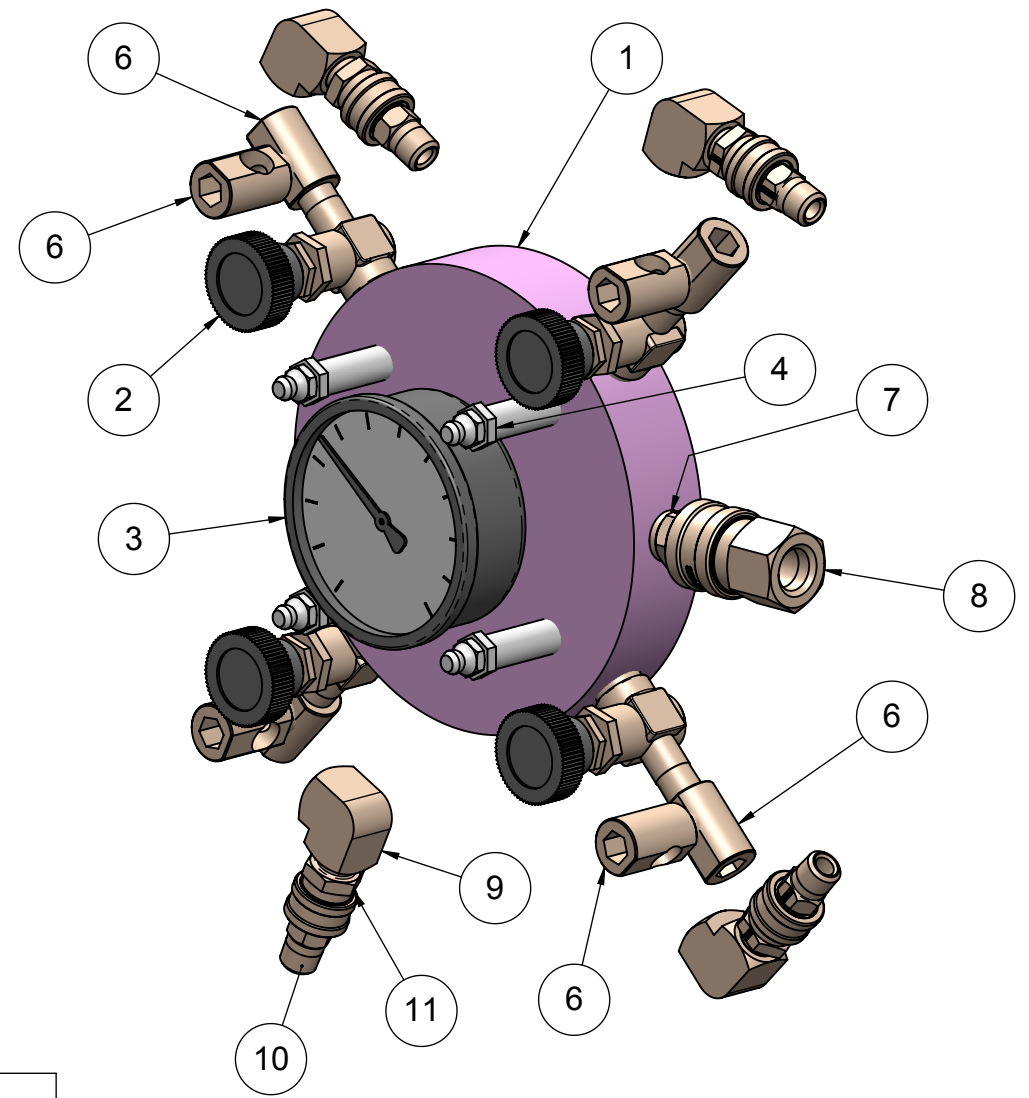
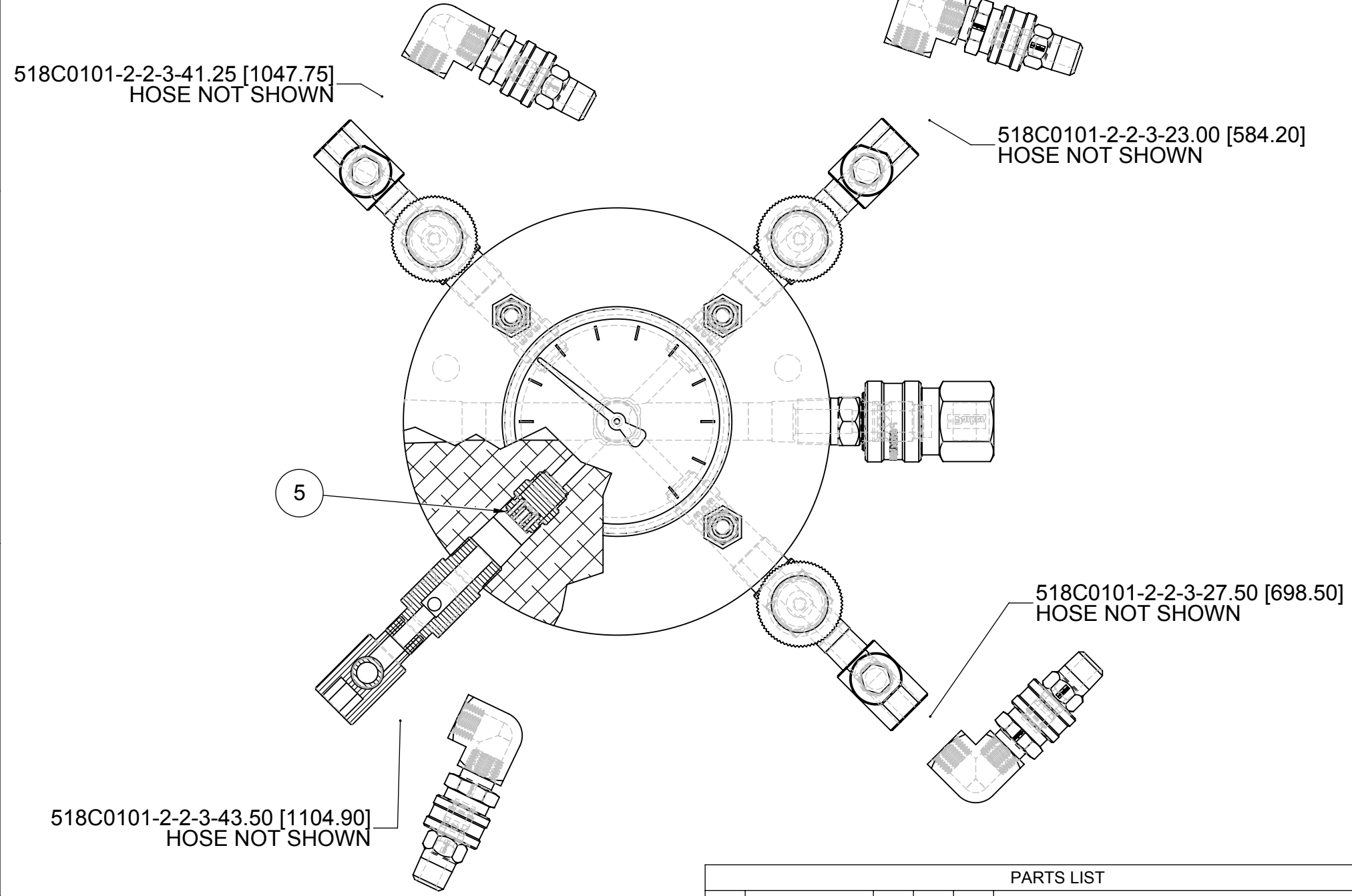

PARTS LIST					
ITEM	REV.	000/Q TY.	U/M	DESCRIPTION	
1	00	1	EA.	4 POINT DIE MANIFOLD BLOCK	
2	00	4	EA.	1/4" MNPT X 1/8 FNPT	
3	00	1	EA.	2" DIAL, 1/4" REAR MOUNT GAUGE	
4	00	4	EA.	1/8" PTF, 1-3/4" HEIGHT	

PARTS LIST					
ITEM	REV.	000/Q TY.	U/M	DESCRIPTION	
5	00	4	EA.	INTERNAL CHECK VALVE	
6	00	8	EA.	1/8 MALE x 1/8 FEMALE PIPE, 90° ELBOW	
7	00	1	EA.	1/4" NIPPLE	
8	00	1	EA.	1/4" COUPLER	
9	00	4	EA.	1/8 NPT ELBOW 90°	
10	00	4	EA.	1/8 NPT NIPPLE	
11	00	4	EA.	1/8 NPT COUPLER	

CUSTOMER  
RPII

FIRST USE

MATERIAL  
See Bill Of Materials

FINISH

UNLESS OTHERWISE SPECIFIED:  
TOLERANCES

ANGULAR DIMENSIONS..... ± 5 deg.  
FRACTIONAL DIMENSIONS..... ± 1/32 in.  
2 PLACE DECIMAL DIMENSIONS ± .015 in.  
3 PLACE DECIMAL DIMENSIONS ± .005 in.

Reymond Products International, Inc.  
 P.O. Box 202  
 Midvale, OH 44653  
 Web: www.reymondproducts.com  
 Tel: 330.339.3583 Fax: 330.339.6809

WEIGHT  
4.88 LBS.

SCALE  
2:3

DATE  
11/6/2012

DRAWN  
dar

TITLE  
**(4) POINT DIE MANIFOLD**

SIZE PART NO.  
B RP99-MP-00044

REV.  
**01**

SHEET  
1 OF 1

4

3

2

1

**ATTENTION**  
 THIS DOCUMENT AND THE DATA DISCLOSED HEREIN OR HEREWITH IS NOT TO BE REPRODUCED, USED, OR DISCLOSED IN WHOLE OR IN PART WITHOUT THE EXPRESSED, WRITTEN PERMISSION OF REYMOND PRODUCTS AND IS SUBJECT TO RETURN UPON REQUEST

REVISIONS				
ECN	REV.	DESCRIPTION	BY	DATE
-	00	ORIGINAL RELEASE	dar	11/06/2012
-	01	ADDED 1095K13 GREASE ZERK; REMOVED 2309K91 GREASE ZERK	JLB	07/24/2013

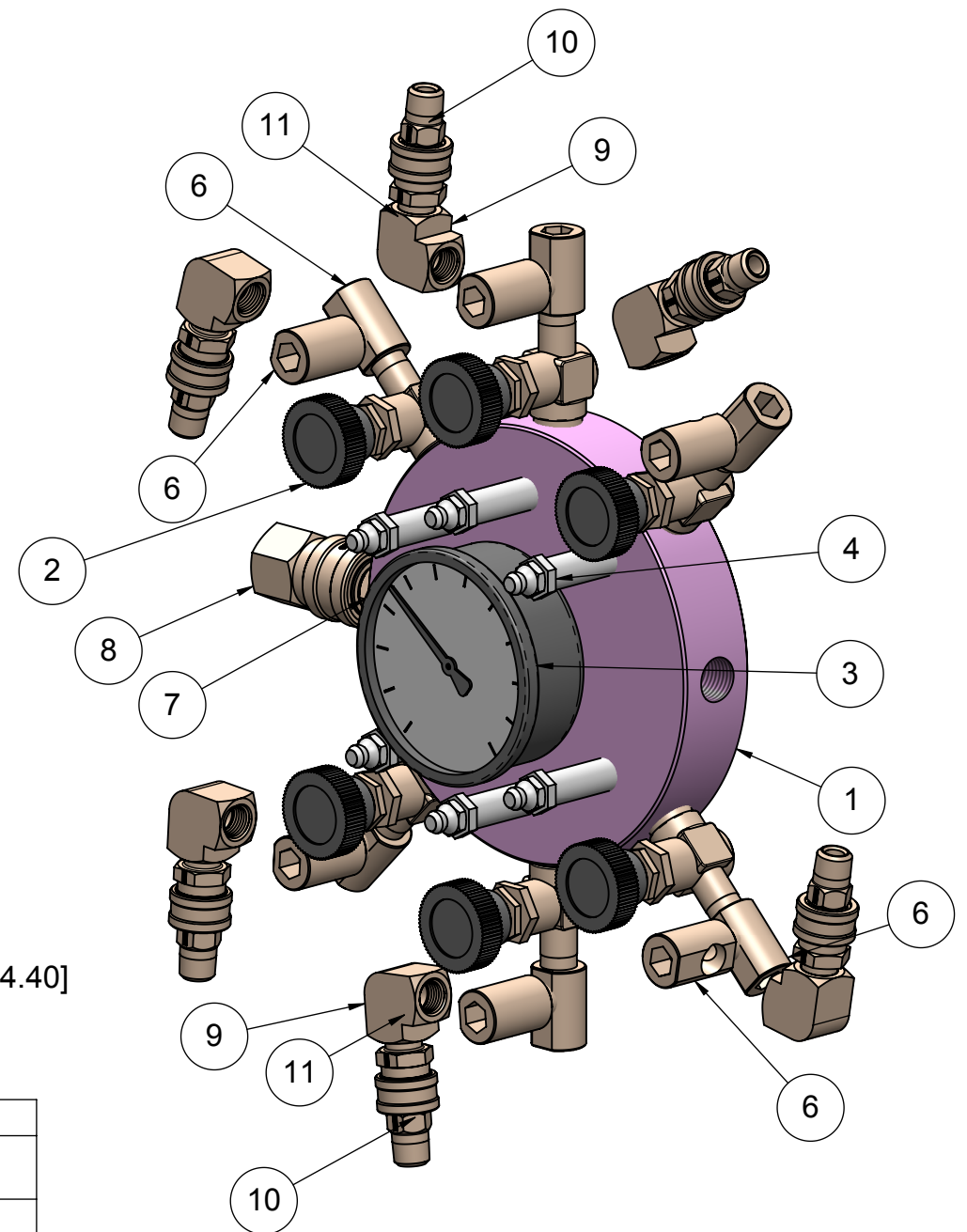
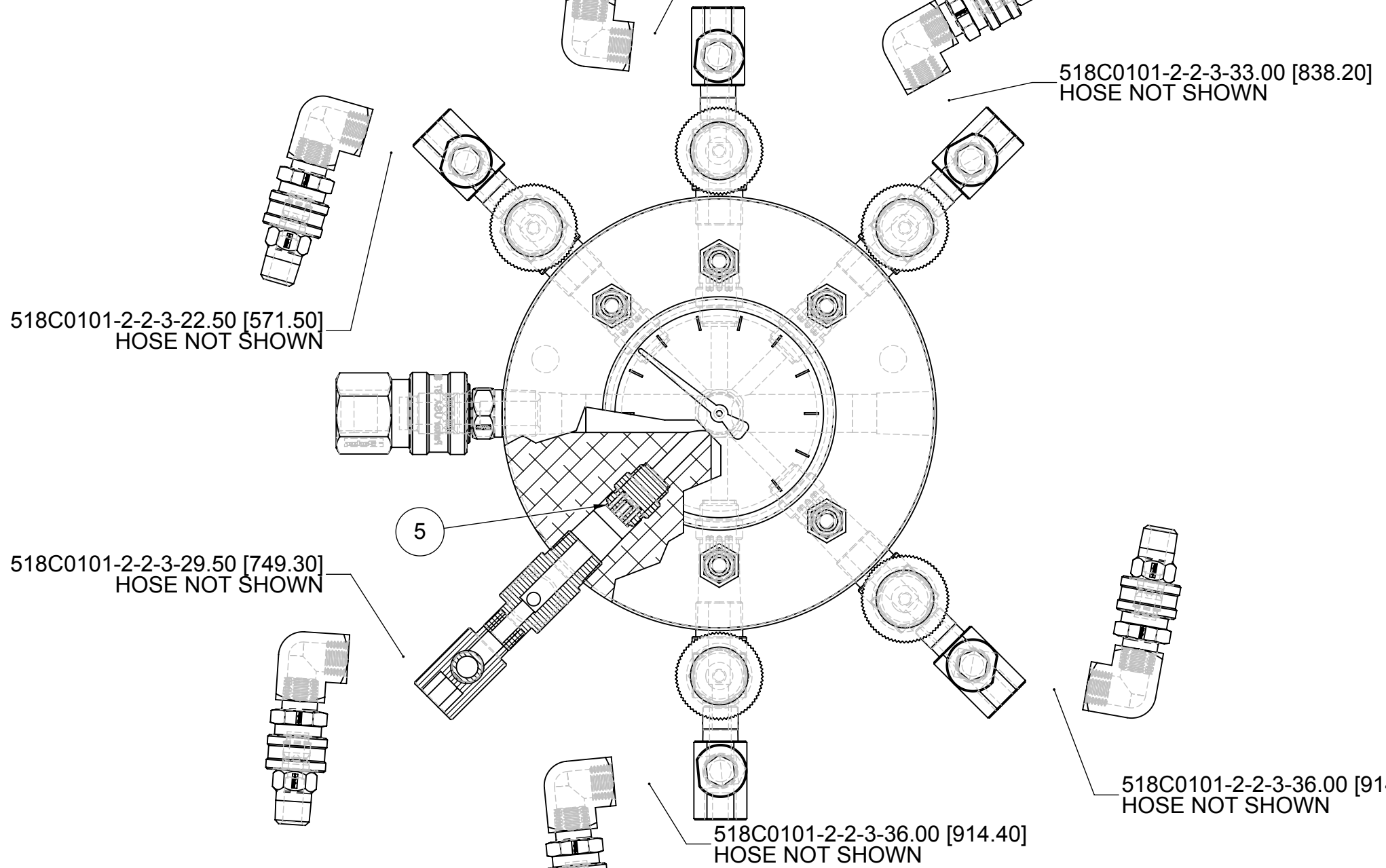

PARTS LIST				
ITEM	REV.	000/Q TY.	U/M	DESCRIPTION
1	00	1	EA.	6 POINT MANIFOLD BLOCK
2	00	6	EA.	1/4" MNPT X 1/8 FNPT
3	00	1	EA.	2" DIAL, 1/4" REAR MOUNT GAUGE
4	00	6	EA.	1/8" PTF, 1-3/4" HEIGHT

PARTS LIST				
ITEM	REV.	000/Q TY.	U/M	DESCRIPTION
5	00	6	EA.	INTERNAL CHECK VALVE
6	00	12	EA.	1/8 MALE x 1/8 FEMALE PIPE, 90° ELBOW
7	00	1	EA.	1/4" NIPPLE
8	00	1	EA.	1/4" COUPLER
9	00	6	EA.	1/8 NPT ELBOW 90°
10	00	6	EA.	1/8 NPT NIPPLE
11	00	6	EA.	1/8 NPT COUPLER

CUSTOMER: RPII  
 FIRST USE:  
 MATERIAL: See Bill Of Materials  
 FINISH:  
 UNLESS OTHERWISE SPECIFIED:  
 TOLERANCES  
 ANGULAR DIMENSIONS: ±.5 deg.  
 FRACTIONAL DIMENSIONS: ± 1/32 in.  
 2 PLACE DECIMAL DIMENSIONS ± .015 in.  
 3 PLACE DECIMAL DIMENSIONS ± .005 in.

Reymond Products International, Inc.  
 P.O. Box 202  
 Midvale, OH 44653  
 Web: www.reymondproducts.com  
 Tel: 330.339.3583 Fax: 330.339.6809

WEIGHT: 5.55 LBS.  
 SCALE: 2:3  
 DATE: 11/6/2012  
 DRAWN: dar

TITLE: (6) POINT REAR OIL RING MANIFOLD  
 SIZE: B PART NO.: RP99-MP-00045 REV.: 01 SHEET: 1 OF 1